

Oplite Technologies—Aviation-Quality LED Task Lighting

Oplite Technologies manufactures superior quality LED precision lighting for aircraft interior lighting. Our products are FAA-PMA approved for Cessna installation. Oplite LED aviation light are made in the United States, and can be purchased worldwide through our distribution network.



Maplight 4 (Single Color)

FFA-PMA Approved For Eligible Cessna Aircraft

Easily installed, dimmable, unobtrusive and efficient, the LED Maplight 4 series consists of four LEDs of the same color that illuminate simultaneously. The LED Maplight 4 series is compatible with all dimming systems.



Maplight 6 (Single or Dual Color)

FFA-PMA Approved For Eligible Cessna Aircraft

The Maplight 6 series is available either with all six LEDs of your color choice operating simultaneously, or three white LEDs and three LEDs of your color choice operating independently of the other color. The Maplight 6 series is compatible with all dimming systems.

Each LED Maplight is manufactured and tested in accordance with FAA-PMA-approved protocols for quality assurance and customer satisfaction. Each Maplight comes with a Cessna installation kit.

Product Details - Series 4 & 6

- 12-volt model; maximum 15 volts DC / 30 MA
 - 24-volt model; maximum 30 volts DC / 15 MA
 - Fully adjustable in two directions
 - Total installed height when at 90° position is 2.125 inches
 - Mounts in 15/32" thru hole; surface mount adapter available
 - Available in four colors/combinations*: green, red, blue, white
- *(combinations Series 6 only)

For Experimental Aircraft

Oplite 4, Oplite 6, or the gooseneck Oplite GN4.

Any of our rugged, top-quality Oplite brand lighting products are a great addition to your custom-built aircraft.

Gooseneck Oplite GN4



Series 4

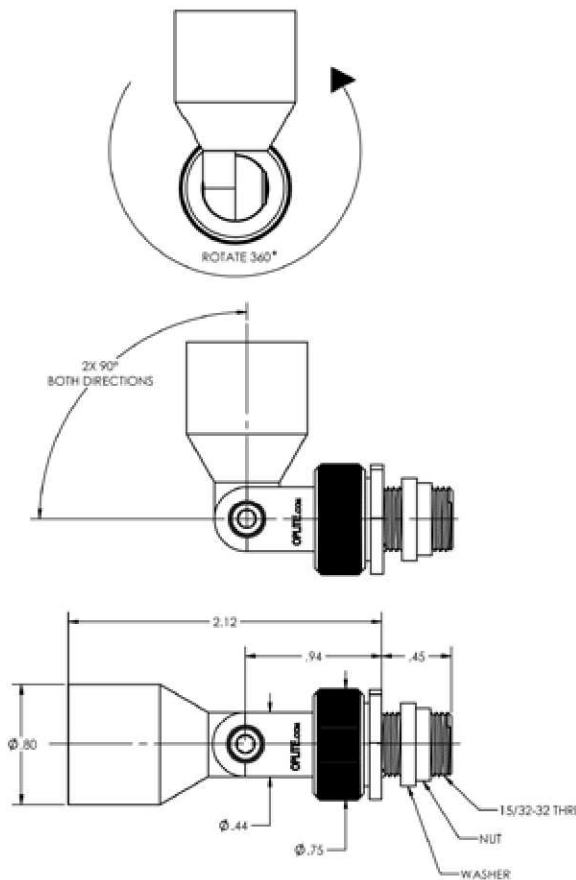

Series 6

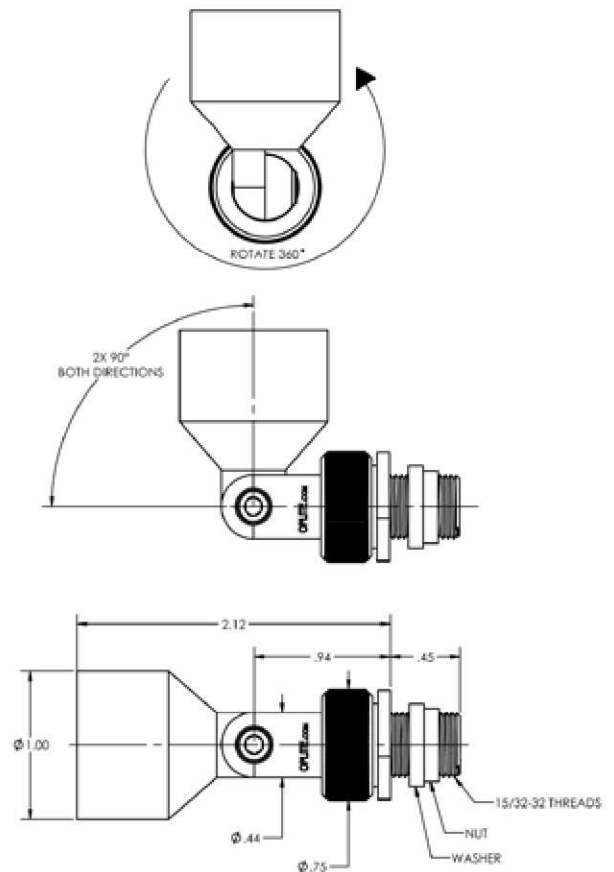

FOR CERTIFIED AIRCRAFT OTHER THAN ELIGIBLE AIRCRAFT:

Installation of FAA-PMA Maplight 4 and Maplight 6 series lights is a minor alteration and does not require an STC or Form 337.

An A&P is required to install or supervise owner installation and document airframe logbook.

Wiring should be installed in accordance with AC 43.13-1B Chapter 11.



MADE IN THE USA

Oplite Technologies is a division of Machine Incorporated, a highly reliable CNC machining company—dependable in both product and customer service. www.machineinc.com



oplite.com

781.297.3700 info@oplite.com

879 Turnpike Street, Stoughton, MA 02072 USA

REVISIONS			
REV.	DESCRIPTION	DATE	APPROVED
-	PRODUCTION RELEASE	3/31/15	DAM



SECTION A-A
SCALE 2:1

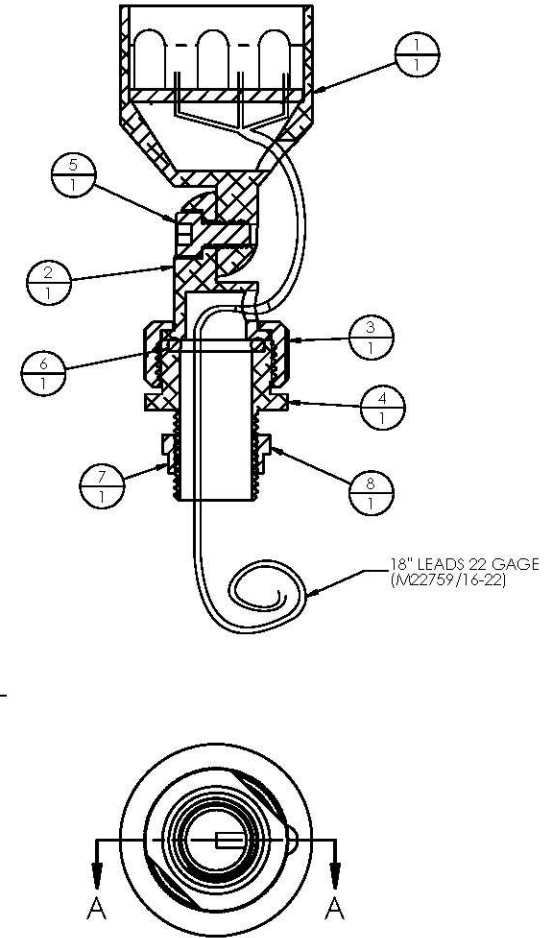

ITEM NO.	PART NUMBER	DESCRIPTION	Default/ QTY.
1	VARIOUS	BEZEL ASSEMBLY	1
2	5002-00	POST	1
3	5003-00	POST NUT	1
4	5001-00/5004-00 (NOT SHOWN)	BASE/ SURFACE MOUNT ADAPTER(OPTIONAL)	1
5	93705A144	6-32 X .250 SCREW	1
6	94115K012	O-RING	1
7	GAYNOR 42-06	15/32-32 BRASS NUT	1
8	GAYNOR 34-08	INTERNAL TOOTH LOCK WASHER	1

LED APPROX LIFE 20,000 HOURS
WEIGHT 1.6OZ
12 VOLT MODEL- MAX 15 VOLTS DC @ 30 MILLIAMPS
24 VOLT MODEL- MAX 30 VOLTS DC @ 30 MILLIAMPS

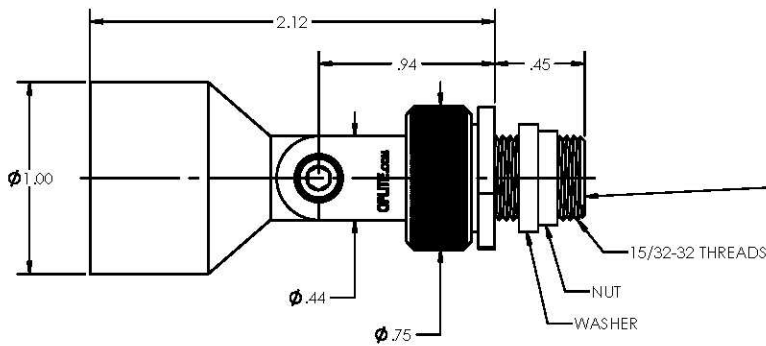
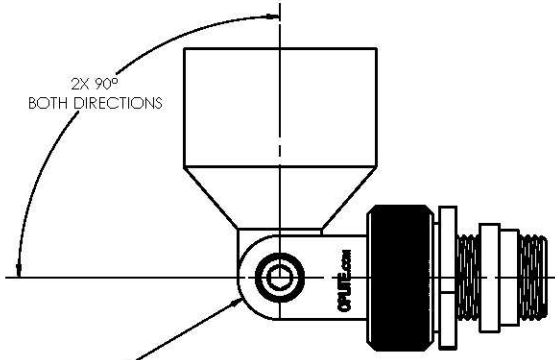
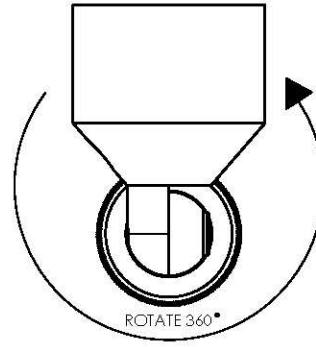

SHOWN IN ALTERNATE
90° BEND OR STRAIGHT VIEWS

- NOTES:
- MATERIAL: SEE PARTS LIST
 - ASSEMBLE AS SHOWN AND LATEST REVISION OF DOC #25-
MAPLIGHT ASSY. PROTOCOL.

UNLESS OTHERWISE SPECIFIED: TOLERANCES ARE: DIMENSIONS ANGLES XX ±.010 ±.01° XXX ±.005 ±.005/2° XXXX ±.000 SURFACES 32 Ra				MACHINE INC. 879 TURNPIKE STREET STOUGHTON, MA 02072	
TITLE: MAPLIGHT 6 SERIES TECH DATA					
THIRD ANGLE PROJECTION		MATERIAL:		DRAWING NO.	
DRAWN BY: DAM		DATE: 3/31/15		C 6000	
APPROVED: RSM		DO NOT SCALE DRAWING		SCALE: 4:1	
DIMENSIONS ARE IN INCHES				SHEET: 1 of 1	