

## TASKLIGHT 600

## FAA NORSEE APPROVED



The Tasklight 600 product is designed and manufactured in the USA to industry leading traceability of ISO 9001 AS9100 quality standards and will provide years of reliable service. Constructed with quality components and 6016-T6 Anodized Aluminum Housing.

This light incorporates an on/off power switch along with a dimming system actuated by a knob at the rear of the housing. The unit is compatible with both 14v and 28v systems.

On dual color models, both color switching and dimming is controlled by the dimming knob.(Turn right for color 1 and opposite direction for color 2 with center position dark)

Voltage: 11V-28V DC  
Power: 40mA max  
Weight: 59.5 g (2.1 oz)

Operating temperature range -25C to +80C  
Storage temperature range -30C to +100C

Light Output, Dual Color Model:  
White: 48k max. MCD (Millicandela Rating)  
Red: 22.5k max. MCD

Light Output, Single Color Model:  
White: 96k max. MCD (Millicandela Rating)  
Red: 45k max. MCD

### Wiring and Installation:

The Tasklight 600 is compatible with both 14v and 28v systems.  
The light is provided with 18" leads of M22759/16-22 wire  
Black lead (-) Color lead (+)  
Tasklight 600 should be installed in accordance with AC 43.13-1B Chapter 11

*Oplite Technologies is [www.oplite.com](http://www.oplite.com) a division of Machine Incorporated, a highly reliable CNC machining company—dependable in both product and customer service. [www.machineinc.com](http://www.machineinc.com)*

# TaskLight 600

# TaskLight 600 Gooseneck

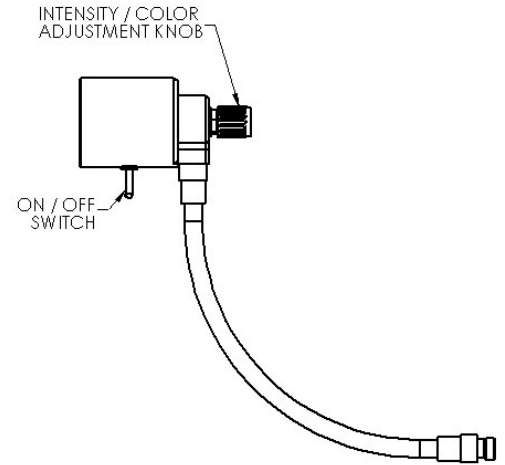
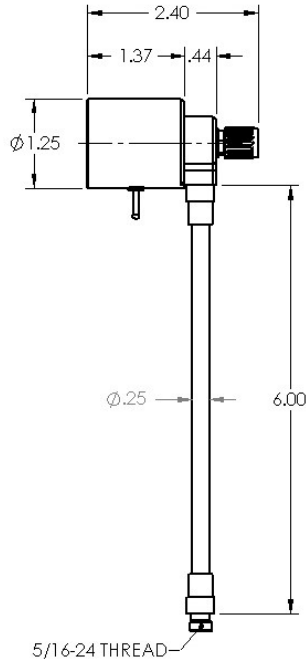
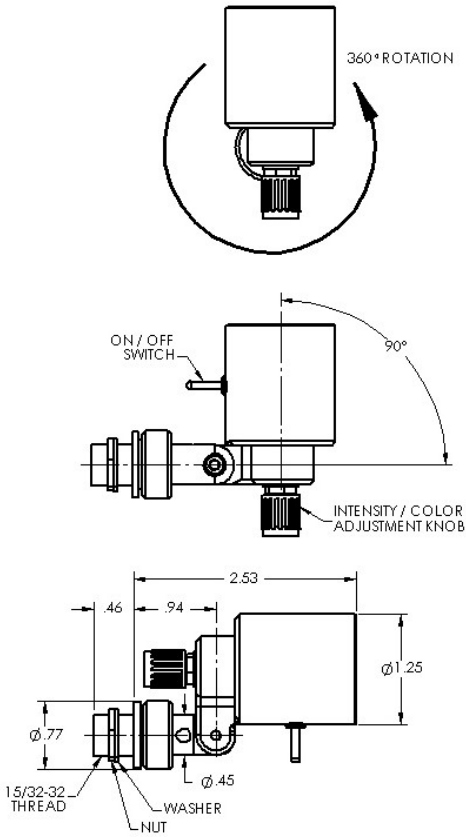

MADE IN THE USA



[www.oplite.com](http://www.oplite.com)

781.297.3700

[info@oplite.com](mailto:info@oplite.com)

879 Turnpike Street, Stoughton, MA 02072 USA

FAA NORSEE APPROVED